

Polymer concrete

Polymer concrete - resin concrete, modern building and construction material, cementless and anhydrous composite made of quartz aggregate in which the traditional cement binder was replaced with a synthetic resin. Replacement of a weak cement paste with a synthetic resin results in a significant change in the properties of polymer concrete, especially the increase in strength, chemical resistance and causes a significant reduction of the material absorption, inaccessible for traditional cement concrete.

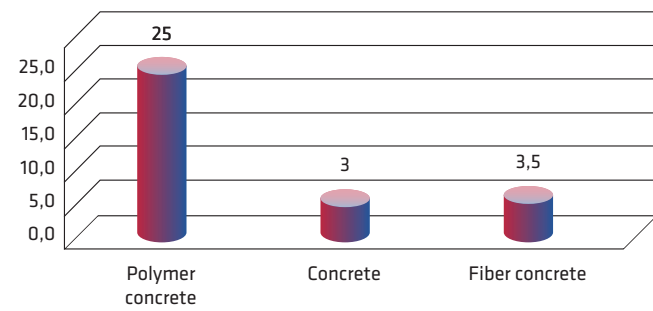

Flexural strength [MPa]



Compressive strength [MPa]

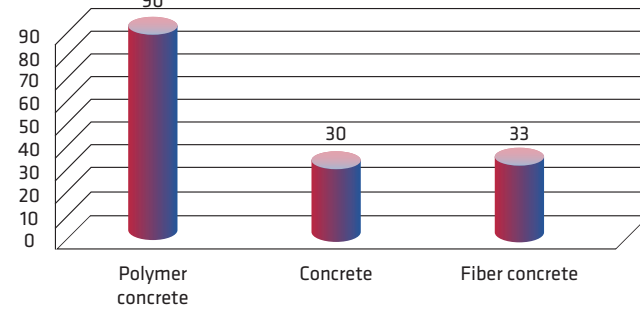

Water absorption [%]

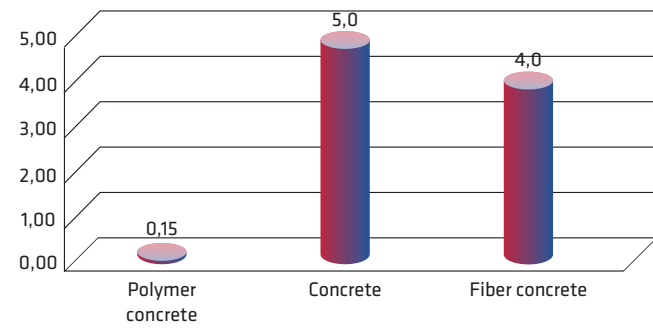

Abrasion value [cm]

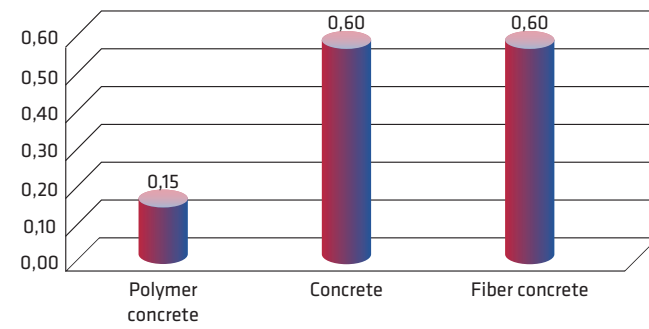

i This folder is of a purely advertising nature and the presented technical solutions are subject to change.

CONTACT DETAILS:

SYSTEMY I TECHNOLOGIE Sp. z o.o.
Ul. Kopalniana 7
59-100 Polkowice, Poland

www.sytec.pl
email: sytec@sytec.pl
tel. +48 76 723 42 35
fax. +48 76 723 42 22

ANCOR Sp. z o.o.
Ul. Kopalniana 5
59-100 Polkowice, Poland

www.ancor.biz.pl
email: ancor@ancor.biz.pl
tel. +48 76 723 42 35
fax. +48 76 723 42 22



KD01B DRAINAGE KERB

PRODUCT DESCRIPTION:

SYTEC KERB DRAINAGE SYSTEM

The solution that performs the functions of the kerb drainage and the linear drainage. The kerbs have inlet oval holes on the side of the road. They meet the requirements of class D400. They are used as linear or as a point drainage. The dimensions of the drainage kerbs closely match to the dimensions of a typical road kerbs of concrete or stone in order to ensure compatibility and the possibility of integration the road drainage kerbs in the sequence of typical concrete or stone kerbs. The repeatability of dimensions enables the installation of the drainage kerbs not only in the newly implemented projects, but also during repairs and reconstruction of

the existing road infrastructure. The kerbs are a perfect solution for drainage of dense buildings of the old towns. Drainage kerbs have a very aesthetic looks that perfectly fits into the image of old towns. The outer part may be in the color of the natural polymer (sand) or tinted according to RAL color palette. According to the standard PN EN1433: 2015 drainage kerbs are the type I of drainage units. This means that they DO NOT REQUIRE CONCRETE BANDS.

1 Drainage kerb 1m

2 Drop kerb 1m

3 Inspection well

4 Closed end cap

5 Open end cap with drain connector

6 Crossover drainage channel

7 Cast iron grating 0.5

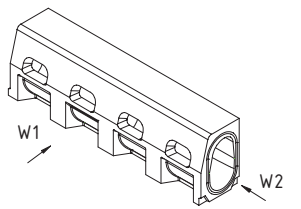
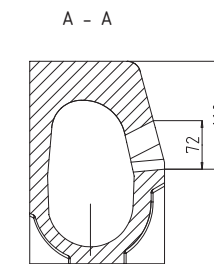
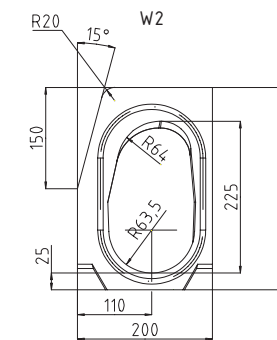
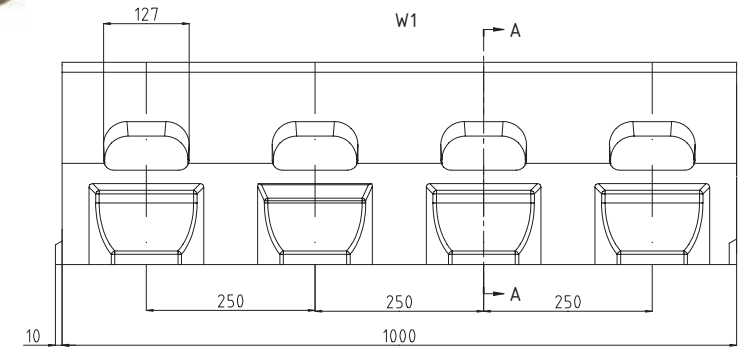
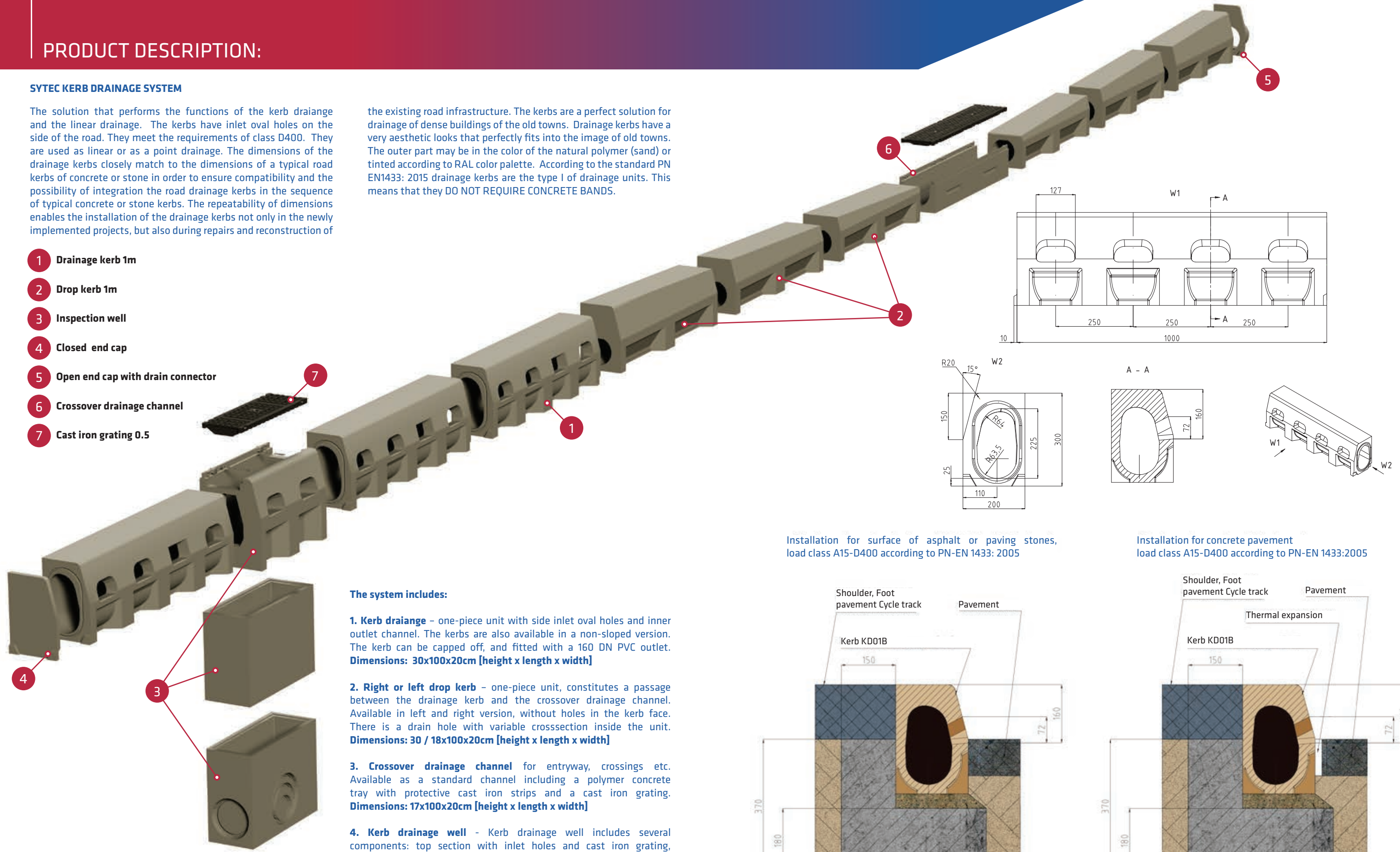

Installation for surface of asphalt or paving stones, load class A15-D400 according to PN-EN 1433: 2005

Installation for concrete pavement load class A15-D400 according to PN-EN 1433:2005

The system includes:

1. Kerb drainage – one-piece unit with side inlet oval holes and inner outlet channel. The kerbs are also available in a non-sloped version. The kerb can be capped off, and fitted with a 160 DN PVC outlet.
Dimensions: 30x100x20cm [height x length x width]

2. Right or left drop kerb – one-piece unit, constitutes a passage between the drainage kerb and the crossover drainage channel. Available in left and right version, without holes in the kerb face. There is a drain hole with variable crosssection inside the unit.
Dimensions: 30 / 18x100x20cm [height x length x width]

3. Crossover drainage channel for entryway, crossings etc. Available as a standard channel including a polymer concrete tray with protective cast iron strips and a cast iron grating.
Dimensions: 17x100x20cm [height x length x width]

4. Kerb drainage well - Kerb drainage well includes several components: top section with inlet holes and cast iron grating, intermediate section and bottom section. Steel strainer basket KOK15 is optional. The grating is fastened with a catch lock.
Dimensions: 78 / 114x100x27 - 20.4cm [height x length x width]

